

BUDG-0025
 BUDG-2045
 BUDG-4065

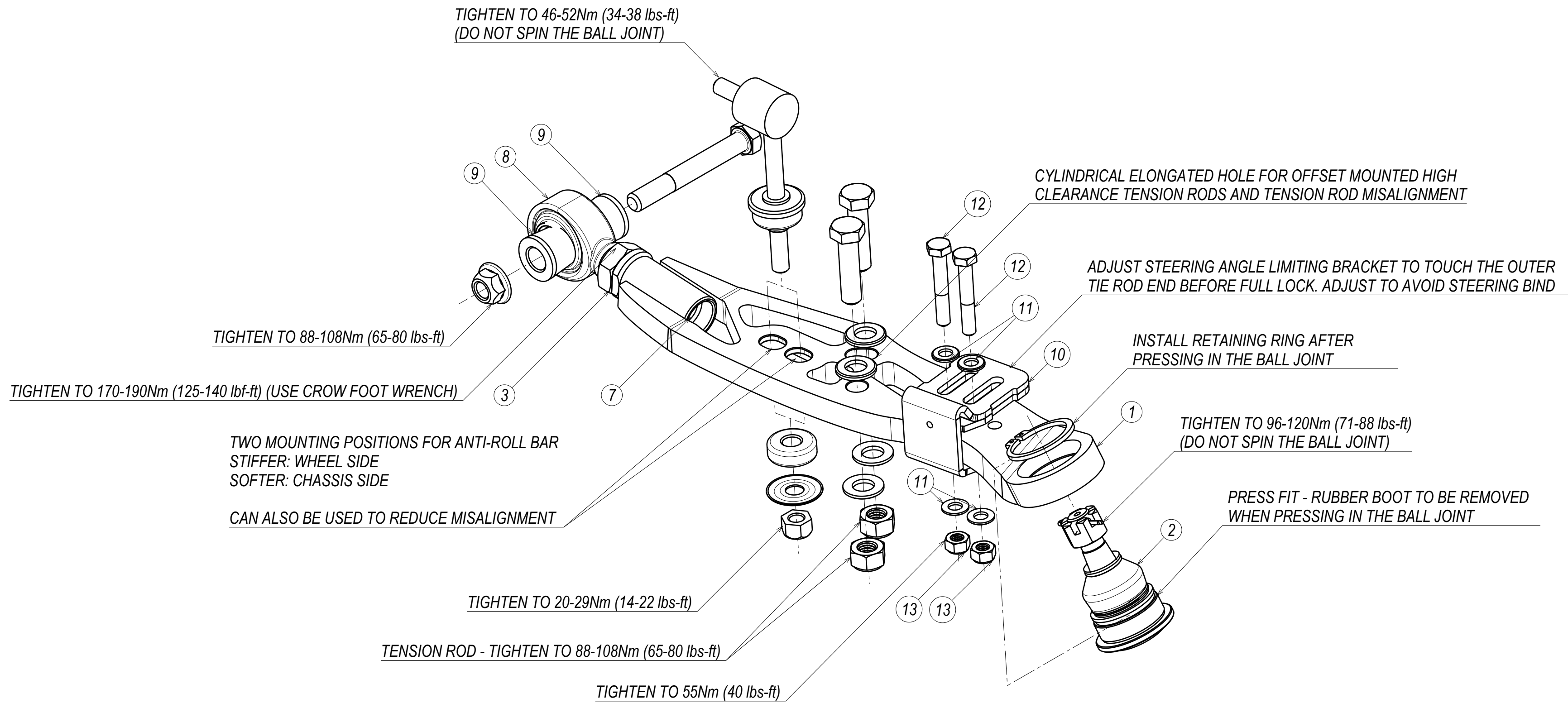

13	LOCK STOP NUT NYLOC DIN 985-8 M8x1.25	2
12	LOCK STOP BOLT ISO 4014 BOLT M8x50 10.9	2
11	LOCK STOP WASHER -SERRAGATED DIN 9250 M8	4
10	LOCK STOP	1
9	ROD END SPACER	2
8	QA1 PCML12T BOOT	1
7	ROD END PCML12T-E L/H THREAD	1
3	ROD END JAM NUT 3/4-16 ASTM A563 L/H THREAD	1
2	OEM TYPE BALL JOINT	1
1	BUDGET LOWER CONTROL ARM BODY	1
PC NO	COMPONENT NAME	QTY

CRITICAL!

CHECK FOR ROD END BEARING ALIGNMENT
 AFTER TIGHTENING THE ADJUSTING MECHANISM
 ROD END TO BE PERPENDICULAR TO THE SPACERS

