

F8XX-DIFF

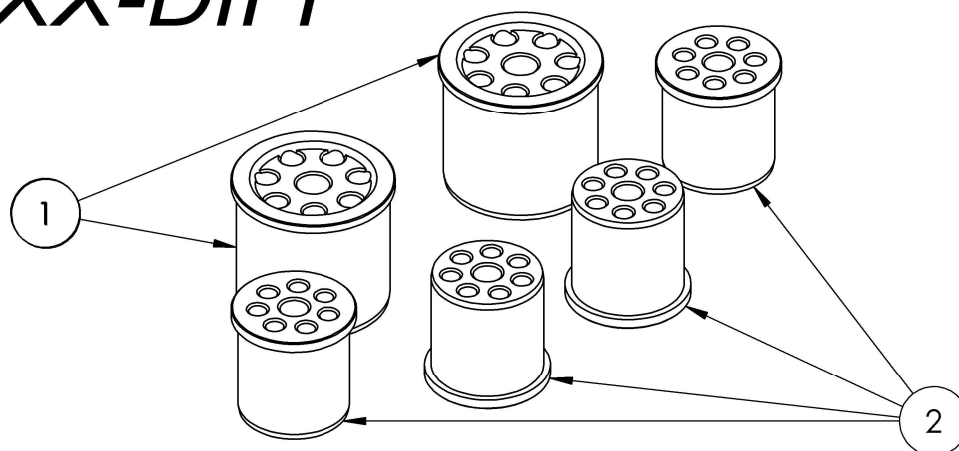

DIAGRAM A

1. REMOVE THE DIFF FROM THE REAR SUBFRAME.
2. PRESS OUT THE OEM REAR BUSH. CLEAN AND GREASE THE OEM AND ADDITIONAL MOUNTING HOLES.
3. USE A PRESS TO REMOVE THE OEM FRONT DIFF BUSHES FROM THE CRADLE. PRESS ON THE INNER SECTION OF THE BUSH AND MAKE SURE TO ADEQUATELY SUPPORT THE CRADLE. IF NOT SUPPORTED CORRECTLY, CRADLE WILL CRACK!
4. USE A RUBBER Mallet (OR HAMMER AND WOOD) TO INSTALL THE REAR BUSHES FROM INSIDE OF THE SUBFRAME.

AGAIN, USE THE PRESS TO INSTALL THE SOLID FRONT DIFF BUSHES, TAKING CARE WITH BUSH ORIENTATION (DIAGRAM B) AND SUPPORTING THE CRADLE THROUGHOUT.

CRITICAL!!! BUSH INSTALL ORIENTATION IS CRITICAL, SEE DIAGRAM B.



DIAGRAM B

5. REINSTALL THE DIFF INTO THE SUBFRAME.

CRITICAL!!! DUE TO ALL BUSHES BEING SOLID, START ALL BOLTS A FEW THREADS FIRST, THEN HAND TIGHTEN THE REMAINDER.

6. TORQUE ALL BOLTS TO THE SPECIFIED VALUES.

ITEM NO.	DESCRIPTION	QTY.
1	F8X REAR DIFF BUSH	2
2	F8X FRONT DIFF BUSH	4