

GT86-BRKT

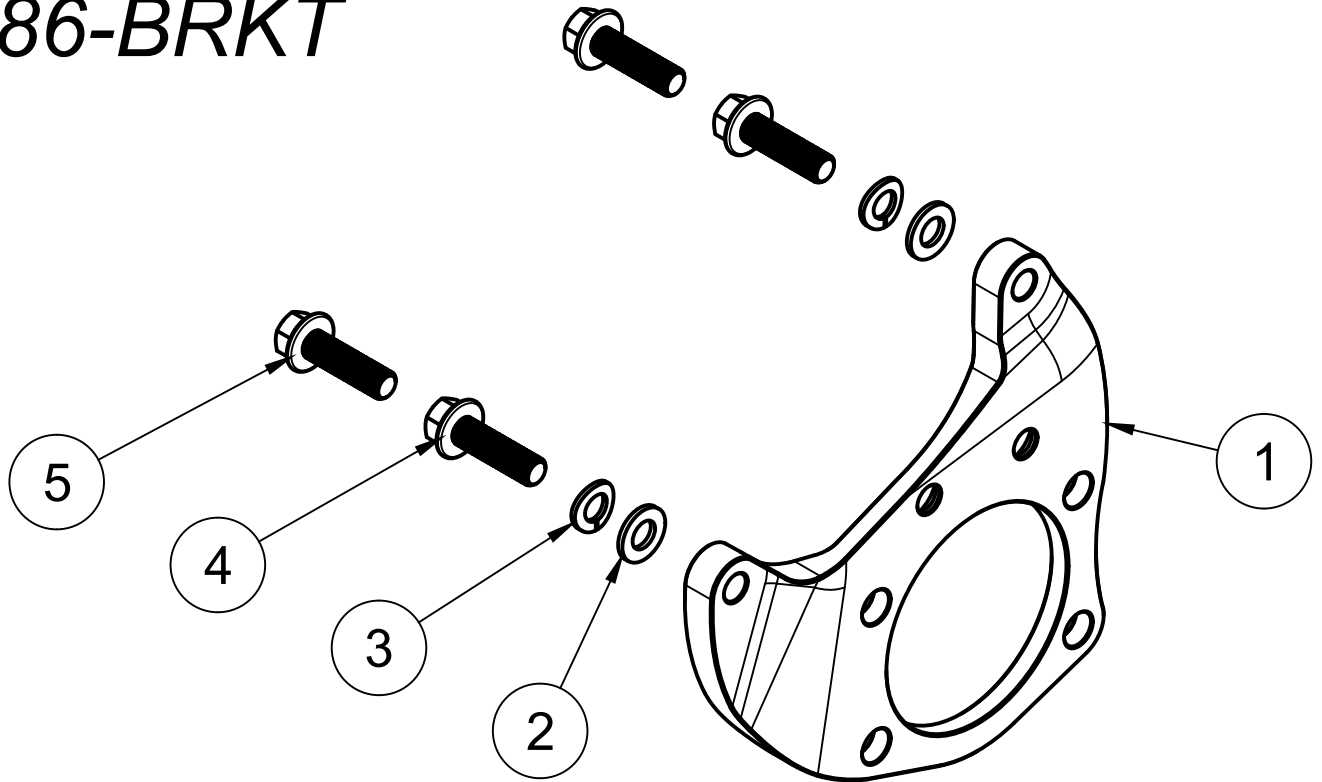

DIAGRAM A

****CRITICAL****

IF YOU INTEND TO USE THE PARKING BRAKE WITH YOUR DUAL CALIPER BRACKET PLEASE REFER TO THE CUSTOMER ASM INCLUDED WITH GT86-TRIP.

1. JACK UP CAR AND REMOVE THE REAR WHEELS.
2. REMOVE BRAKE CALIPER BOLTS AND HANG / PLACE THE CALIPER TO ONE SIDE.
3. REMOVE THE BRAKE DISK AND DRIVESHAFT BOLT.
4. UNDO THE HUB BOLTS FROM BEHIND THE UPRIGHT AND PULL THE HUB AND DUST SHIELD OFF THE UPRIGHT.
5. REMOVE THE CENTRE CONSOLE AND DISCONNECT THE HANDBRAKE CABLE. ALSO UNDO ANY SHROUDS OR CLIPS WHICH RETAIN THE CABLE SO THAT THE DUST SHIELD CAN BE REMOVED (WITH CABLE ATTACHED).
6. REMOVE THE PARKING BRAKE SHOES AND SPRINGS FROM THE DUST SHIELD.

5	M10 x 1.5 FLANGE HEAD BOLT (FOR BREMBO CALIPER)	4
4	M10 x 1.25 FLANGE HEAD BOLT (FOR NON-BREMBO CALIPER)	4
3	M10 SPRING WASHER	4
2	M10 WASHER	4
1	DUAL CALIPER BRACKET	2 (LH AND RH)
ITEM	DESCRIPTION	QTY
PARTS LIST		

gktech
.com

GT86-BRKT

7. BEFORE REINSTALLATION, THE DUST SHIELD AND PARKING BRAKE MECHANISM MUST BE MODIFIED TO ACCEPT THE DUAL CALIPER BRACKET.

DRILL OUT THE SPOT WELDS AS SHOWN IN DIAGRAM B.

GRIND FLAT THE RETENTION PINS THAT PROTRUDE AT THE REAR OF THE DUST SHIELD.

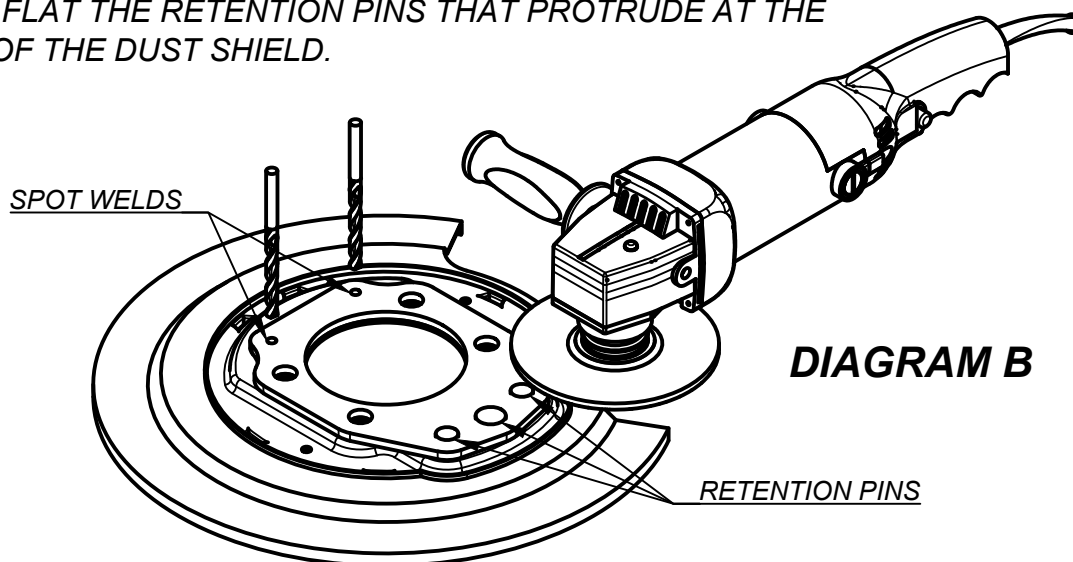

8. USE A PUNCH TO ON THE RETENSION PINS TO SEPERATE THE OEM ANCHOR PIN AND BACKING PLATE FROM THE DUST SHIELD.

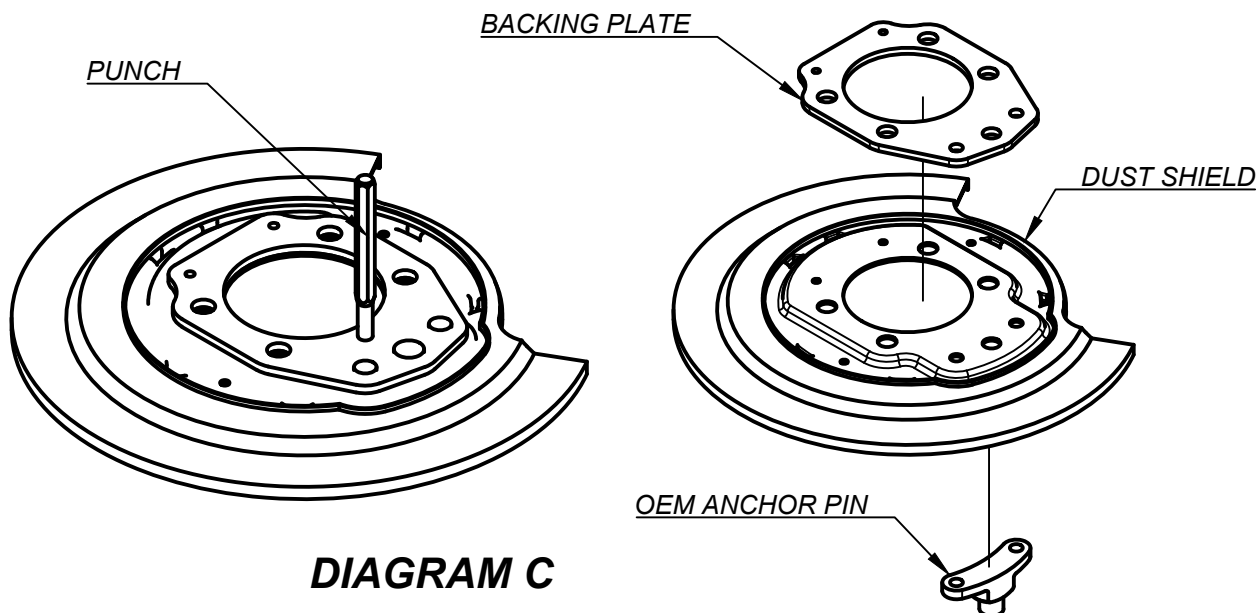

9. REMOVE THE HANDBRAKE CABLE FROM THE DUST SHIELD.
10. THE OEM ANCHOR PIN, BACKING PLATE AND HANDBRAKE CABLE CAN NOW BE DISCARDED.

GT86-BRKT

11. BRIEFLY INSTALL THE DUAL CALIPER BTACKET AND HUB ON TO THE DUST SHIELD AS SHOWN IN DIAGRAM D.

INSTALL THE FOUR BOLTS ONLY FINGER TIGHT TO ENSURE THE PARTS ARE CONCENTRIC AND CORRECTLY ALIGNED.

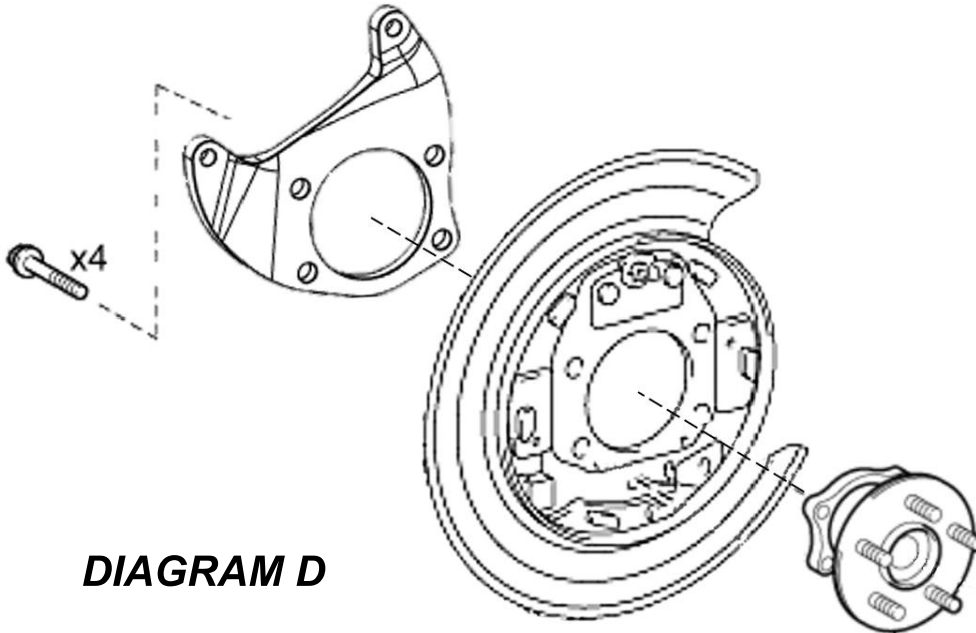

DIAGRAM D

THE DUAL CALIPER BRACKETS CAN BE RUN WITH OR WITHOUT A DUST SHIELD. TO RUN WITHOUT THE DUST SHIELD, THE PARKING BRAKE ASSEMBLY WILL BE DESTROYED AND WILL NOT BE ABLE TO BE USED WITH GT86-TRIP.

12. TO RUN WITH THE DUST SHIELD, USE A PAINT PEN TO MARK ON IT AS SHOWN IN DIAGRAM E (A). BE SURE TO MARK THE OUTER DUST SHIELD AS WELL AS THE STRAIGHT EDGE.

TO PERMANENTLY REMOVE THE DUST SHIELD AND PARKING BRAKE, SIMPLY TRACE THE OUTLINE OF THE HUB AS SHOWN IN DIAGRAM E (B).

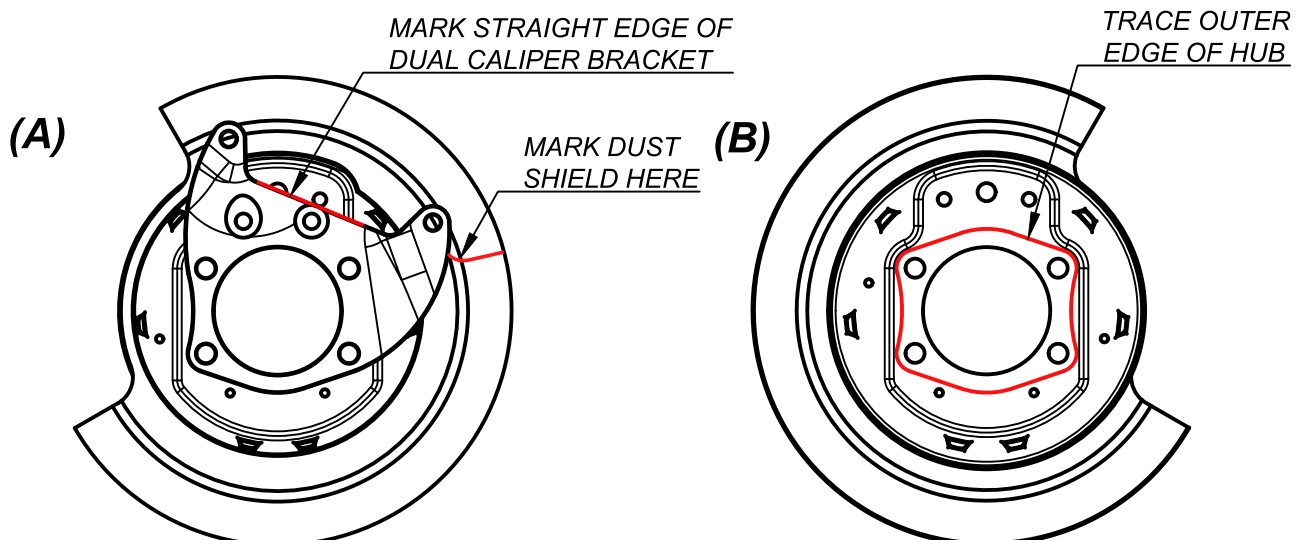

DIAGRAM E

GT86-BRKT

13. *DISASSEMBLE AND ISOLATE THE DUST SHIELD BEFORE CONTINUING.*
14. *FOR **PERMANENT REMOVAL OF THE DUST SHEILD AND PARKING BRAKE**, CUT AROUND THE OUTLINE TO CREATE A SPACER LIKE SHOWN IN DIAGRAM F (B). SKIP AHEAD TO STEP 17.*
15. *REMOVE THE RAISED SECTION OF THE DUST SHIELD ALONG THE MARKED LINE. THIS WILL REQUIRE TWO CONTROLLED CUTS: ONE SHALLOW CUT ALONG THE MARKED LINE, AND ONE RADIAL CUT TO REMOVE THE REMAINING METAL. AFTER, ENSURE THAT THERE ARE NO REMAINING RAISED SECTIONS IN THIS AREA.*

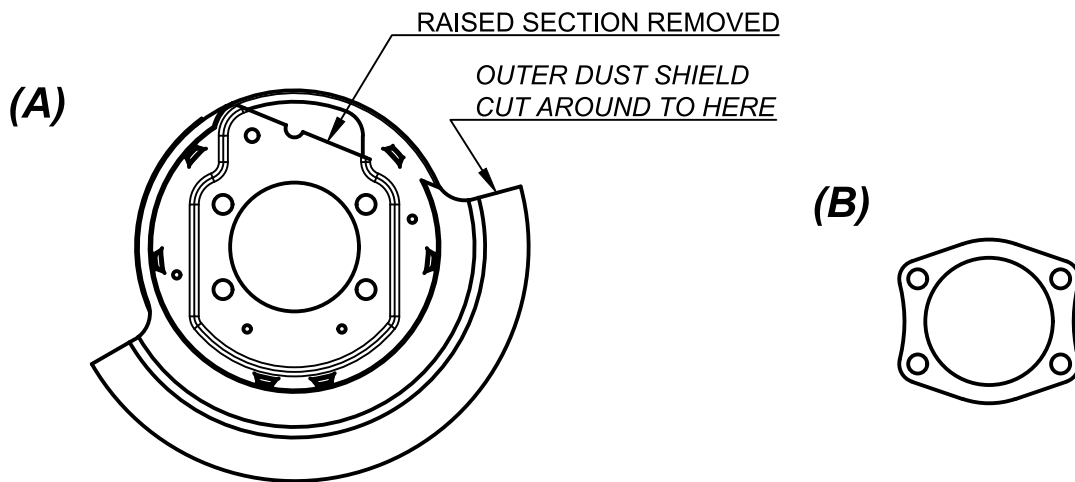

DIAGRAM F

16. *IF RUNNING THE DUST SHIELD, PERFORM A TEST FIT (INCLUDING SECOND CALIPER) TO ENSURE NO ADDITIONAL CUTTING / TRIMMING OF THE DUST SHIELD IS REQUIRED.*
17. *PAINT THE DUST SHIELD / PLATE TO INHIBIT RUST AND CORROSION.*
18. *ASSEMBLE THE DUAL CALIPER BRACKET AND DUST SHIELD AS SHOWN IN DIAGRAM G.*

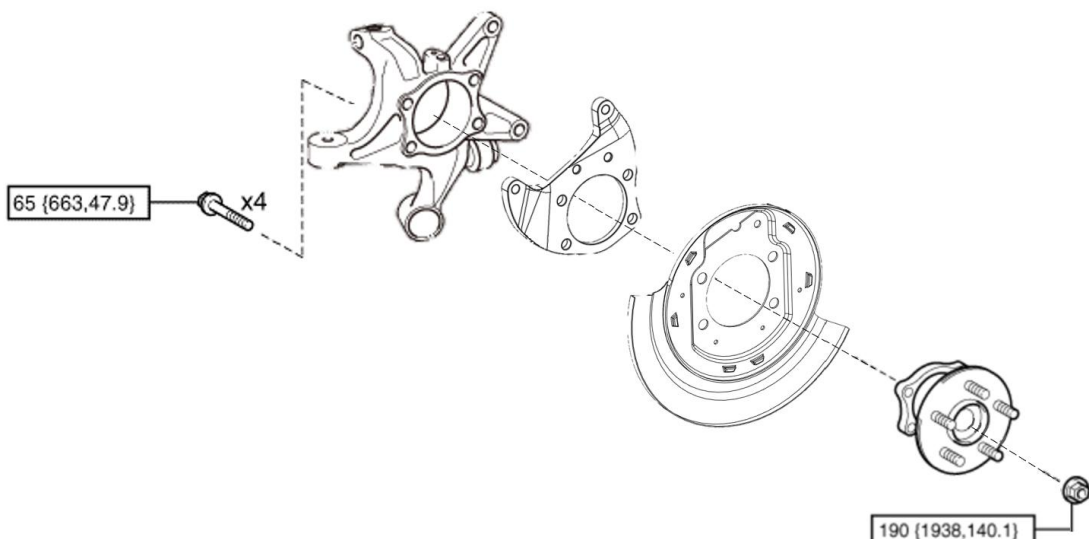

DIAGRAM G

GT86-BRKT

19. INSTALL THE BRAKE ROTOR AND BOTH CALIPERS AS SHOWN BELOW, AND USING THE WASHERS SUPPLIED IN THE ORDER SHOWN IN DIAGRAM A.

(FOR NON-BREMBO, USE M10 x 1.25 BOLTS. FOR BREMBO, USE M10 x 1.5 BOLTS)

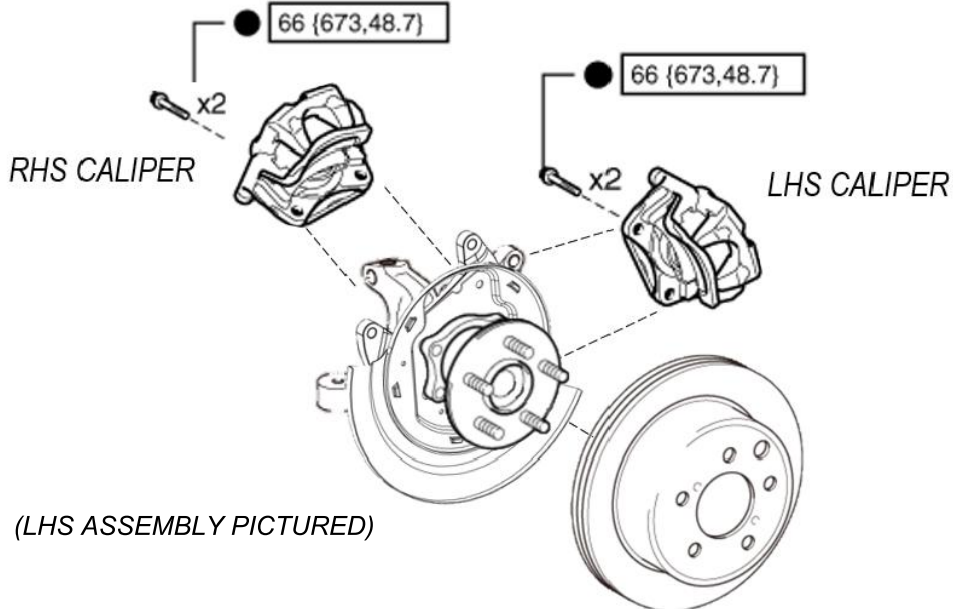

DIAGRAM H

20. INSTALL THE PLUMBING FOR THE SECONDARY BRAKE CALIPERS AND BLEED THE LINES.
21. FOR OEM SECONDARY CALIPERS. WHEN REFITTING THE OEM BRAKE LINE, THE MOUNTING LOCATION TO THE UPRIGHT IS OBSTRUCTED.

THEREFORE, WE RECOMMEND DRILLING OUT THE MOUNTING HOLE USING A 12MM DRILL BIT AND MOUNTING IT BELOW THE THE UPPER CONTROL ARM USING ITS LOCKING BOLT AS PICTURED IN DIAGRAM I.

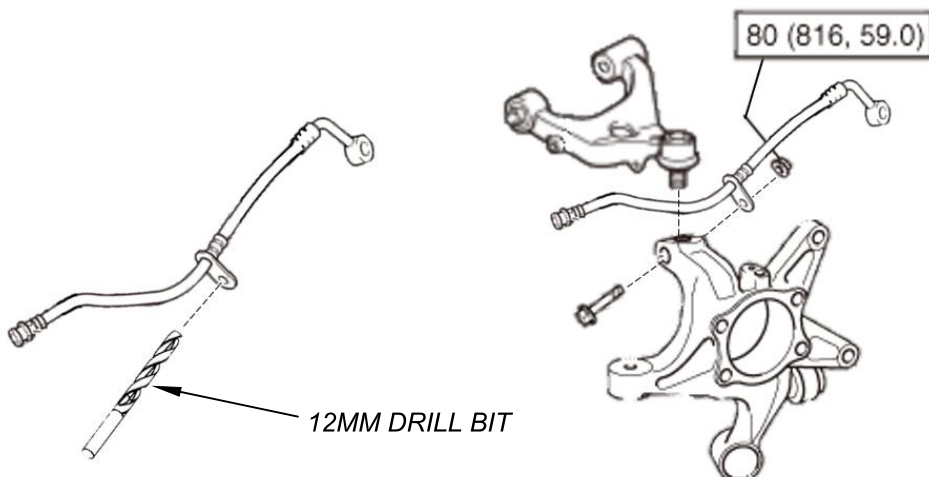

DIAGRAM I

22. FIT THE WHEELS AND LOWER THE CAR.