

CRITICAL!

CHECK FOR ROD END BEARING MISALIGNMENT. AFTER TIGHTENING THE ADJUSTING MECHANISM ROD END TO BE AS PARALLEL TO THE SPACERS AS POSSIBLE

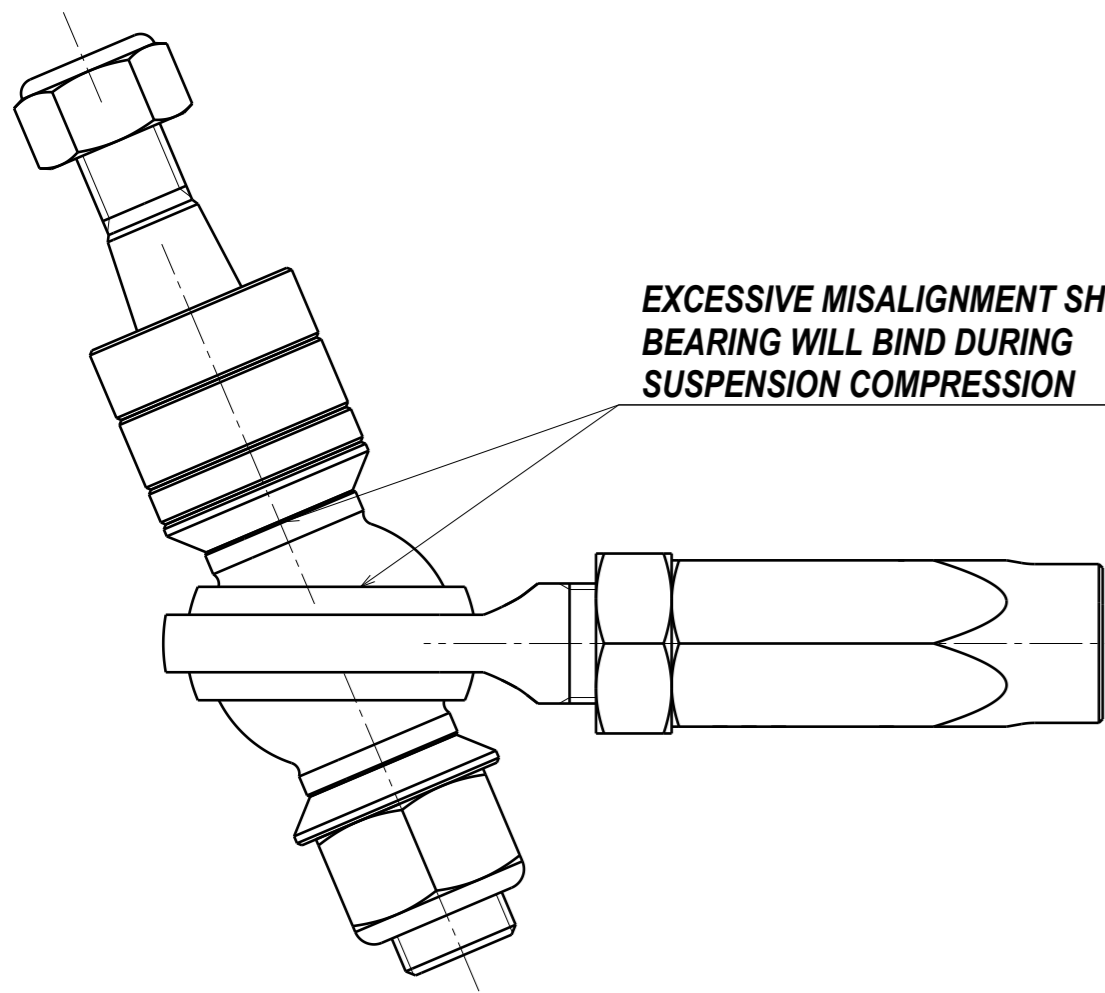

EXCESSIVE MISALIGNMENT SHOWN - BEARING WILL BIND DURING SUSPENSION COMPRESSION

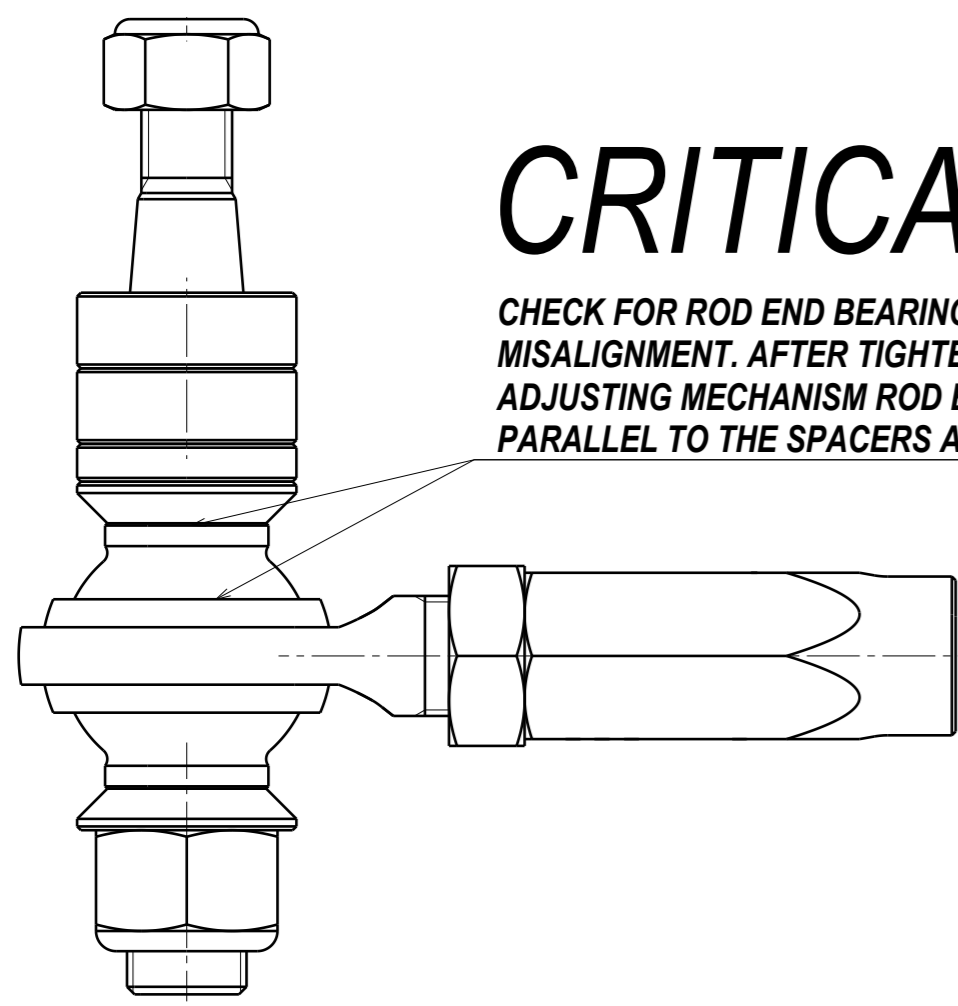
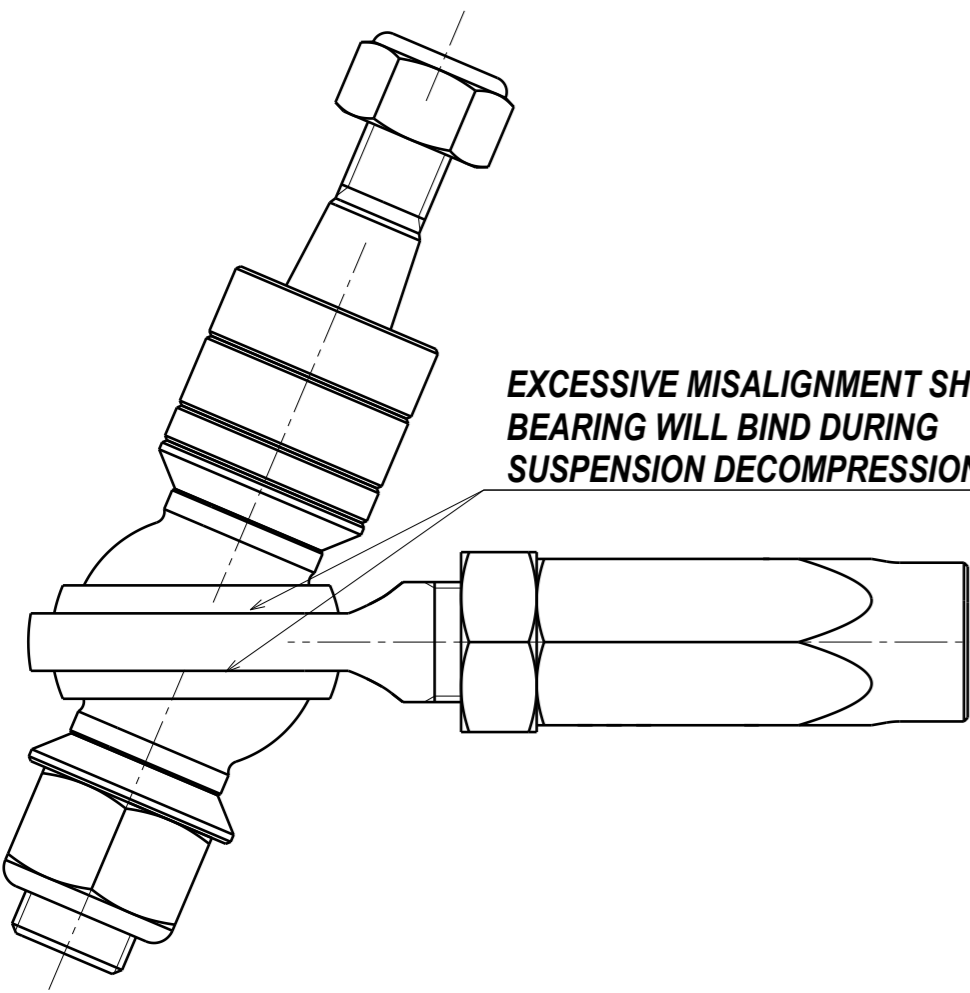

EXCESSIVE MISALIGNMENT SHOWN - BEARING WILL BIND DURING SUSPENSION DECOMPRESSION

3. INSTALL ROD END DUST BOOT OVER ROD END (THREADED END TO GO THROUGH LARGER HOLE FIRST)

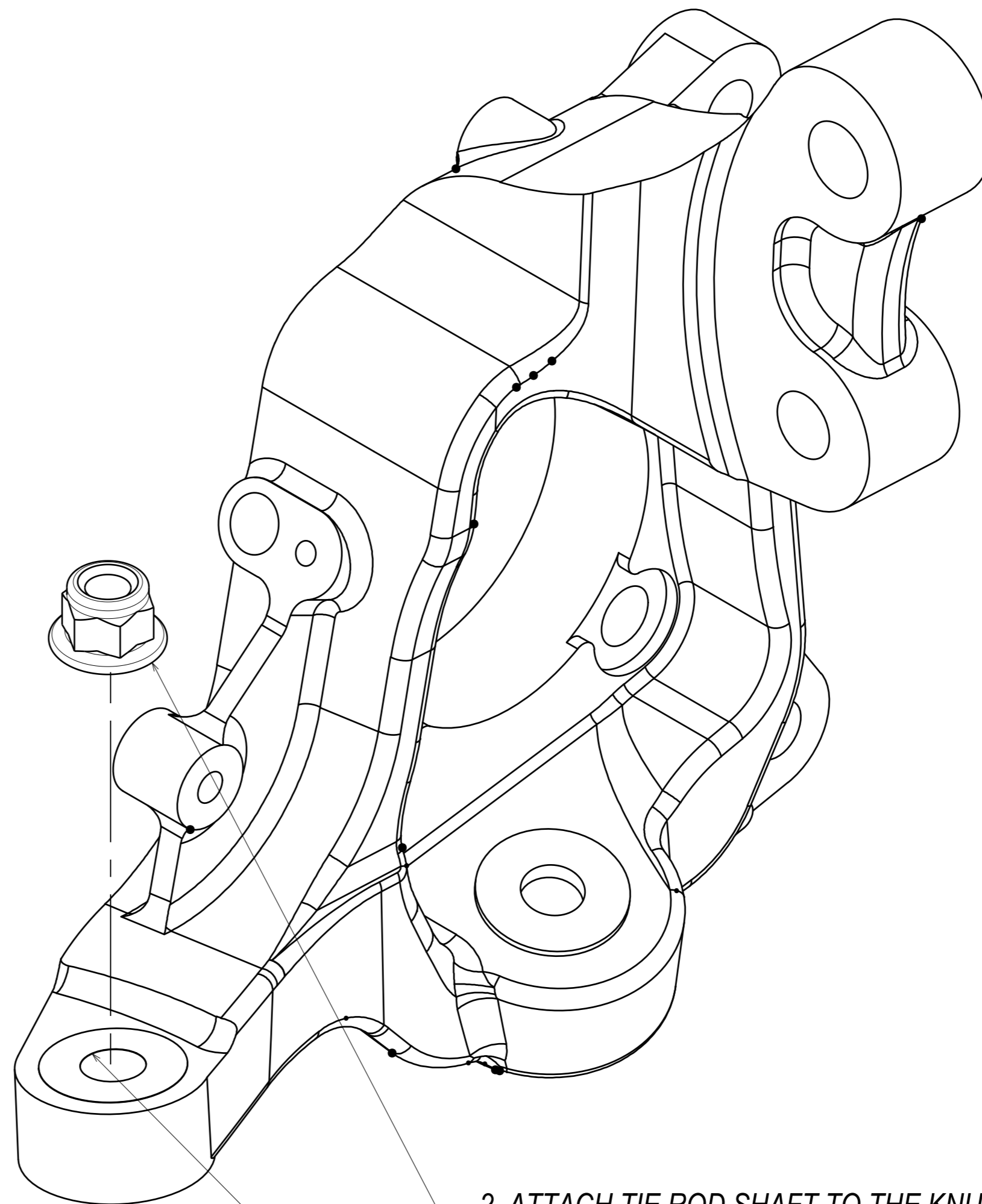

2. ATTACH TIE ROD SHAFT TO THE KNUCKLE AND TIGHTEN NUT TO 70 Nm (50 lb-ft)

1. TAPERED HOLE TO BE CLEANED BEFORE INSTALLATION

INSTALLATION SPACER

OUTER TIE ROD SHAFT CAN BE CUT SHORTER FOR MORE WHEEL CLEARANCE

4. INSTALL SPACERS AND ROD END OVER TIE ROD SHAFT

7. TIGHTEN NUT TO 120 Nm (90 lb-ft)

6. INSTALL INNER TIE ROD THREAD ADAPTER

9. TIGHTEN NUT TO 40 Nm (30 lb-ft)

8. INSERT INNER TIE ROD

INSTALLATION SPACER

5mm SPACER

10mm SPACER

5. TIGHTEN NUT TO 90 Nm (65 lb-ft)

SPACERS INCLUDED IN THE KIT TO ADJUST THE HEIGHT OF THE ROD END TO CORRECT BUMPSTEER. INSTALLATION SPACERS MUST ALWAYS BE USED.

OEM position

15mm corrected position

