

# REAR-LCAX

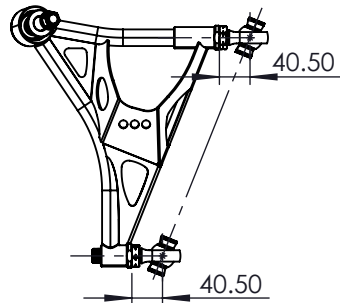

**MIN LENGTH**

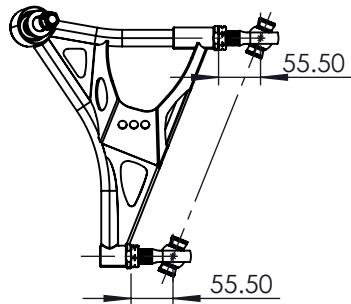

**OEM LENGTH**

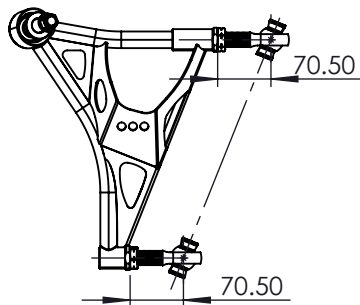

**MAX LENGTH**

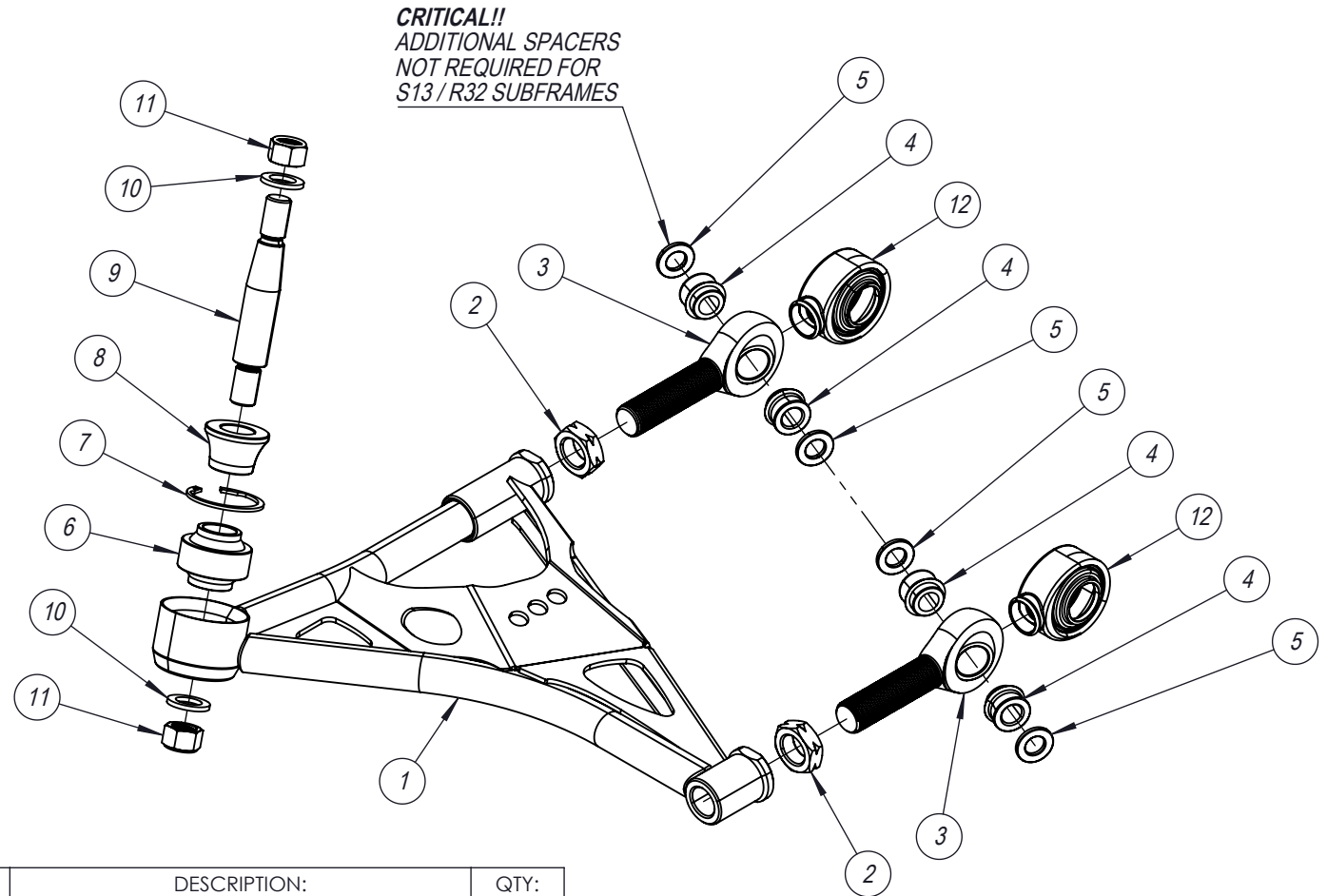

ITEM NO.	DESCRIPTION:	QTY:
1	S-CHASSIS RLCA WELDED ARM	1
2	NUT 3/4-16 UNF 3B L/H	2
3	PCML12T-ES	2
4	SPACER PCML12T 12ID 45W HIGH MISALIGNMENT	4
5	SPACER 12X24X2.5	4
6	YPB12-T	1
7	INTERNAL RETAINING RING	1
8	SHANK SPACER STD LENGTH	1
9	SHANK S14/S15 FRONT STD LENGTH	1
10	DIN 433 M14X24X2.3 WASHER	2
11	LOCK NUT	2
12	PCMX12T ROD END COVER	2

## CRITICAL!

CHECK FOR ROD END BEARING ALIGNMENT  
AFTER TIGHTENING THE ADJUSTING MECHANISM  
ROD END TO BE PERPENDICULAR TO THE SPACERS

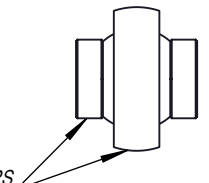

# REAR-LCAX

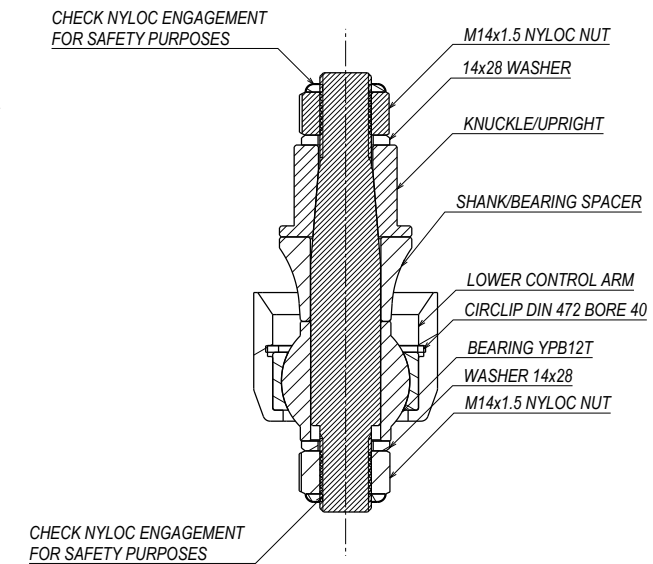
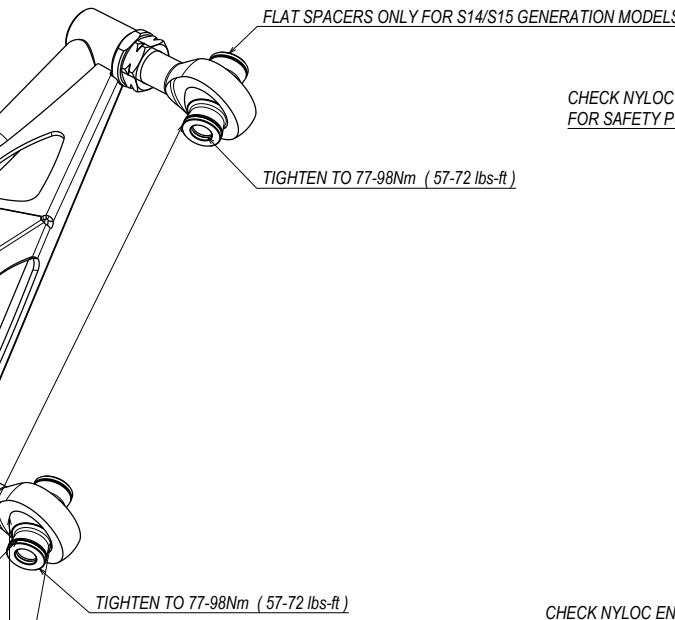
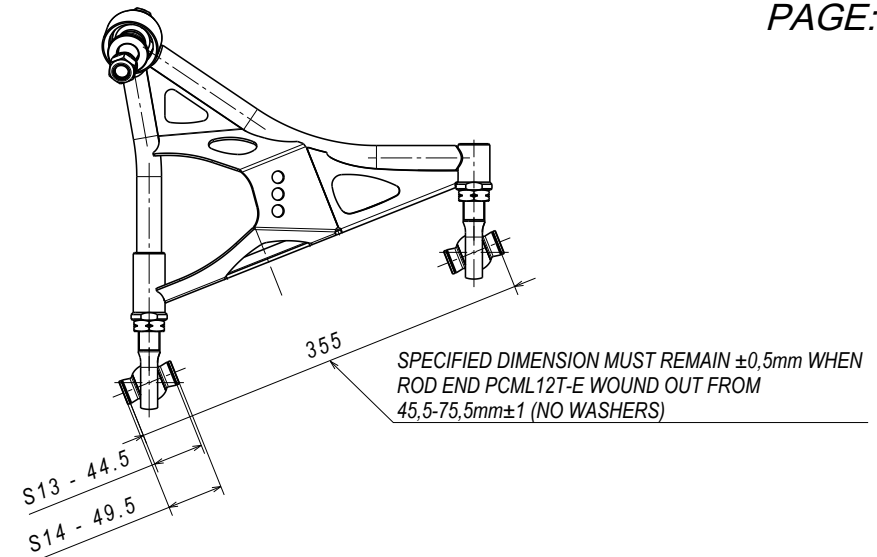
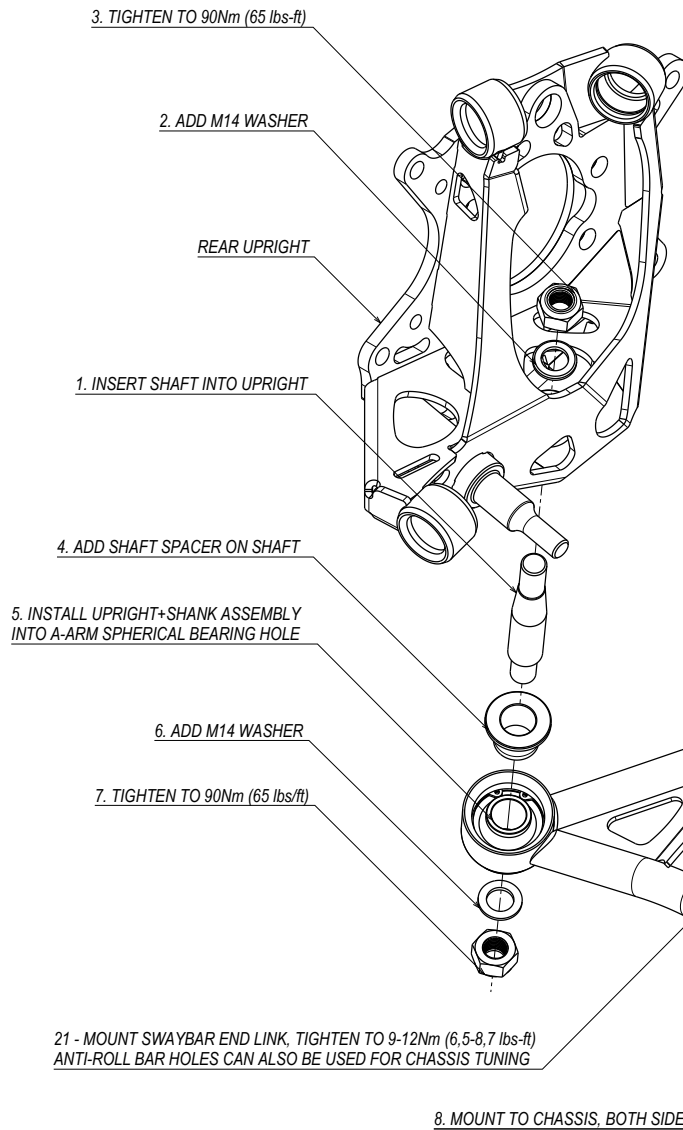

**CRITICAL!**  
CHECK FOR ROD END BEARING ALIGNMENT AFTER TIGHTENING THE ADJUSTING MECHANISM  
ROD END TO BE PERPENDICULAR TO THE SPACERS