

S13X-TRTN

1. Clean the surfaces of the OEM traction rod by removing rust and paint in the areas which you intend to weld.
2. Install the reinforcement into the OEM traction rod. Ensure that the fitment is tight and that the reinforcement is sitting level (pressing down on the centre of the reinforcement can create a small bend and improve fitment).

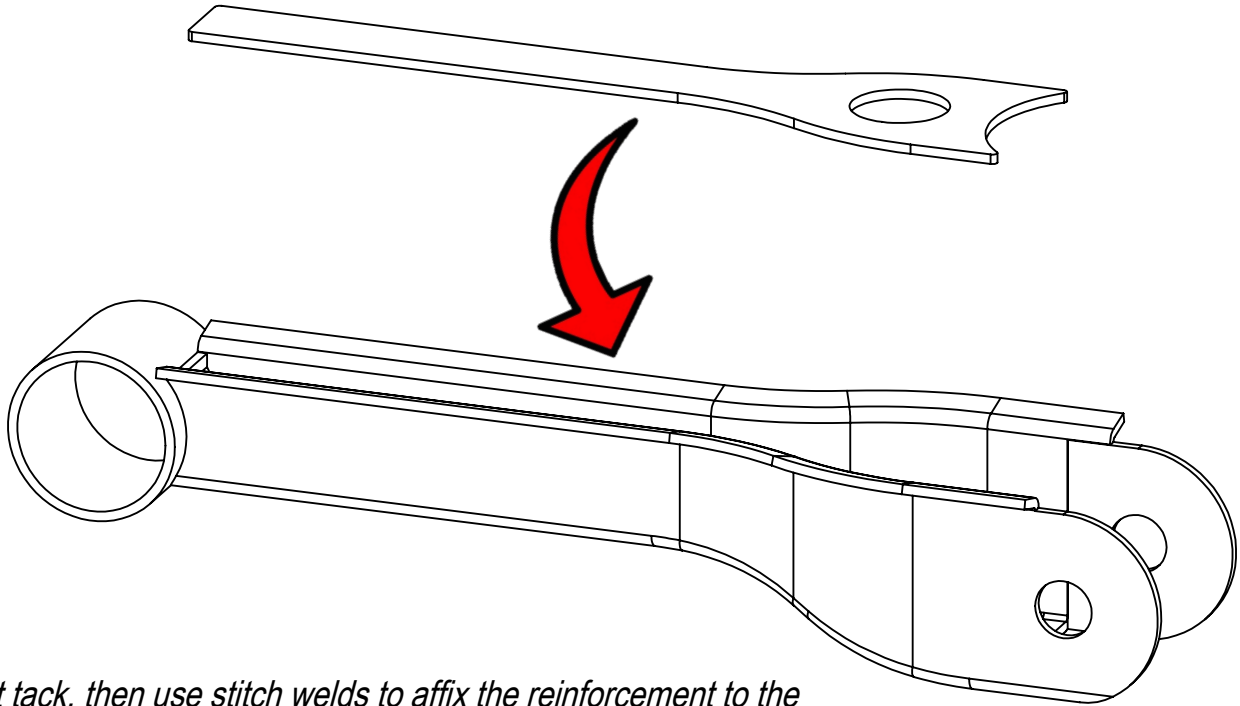

3. First tack, then use stitch welds to affix the reinforcement to the traction rod at the locations highlighted below.

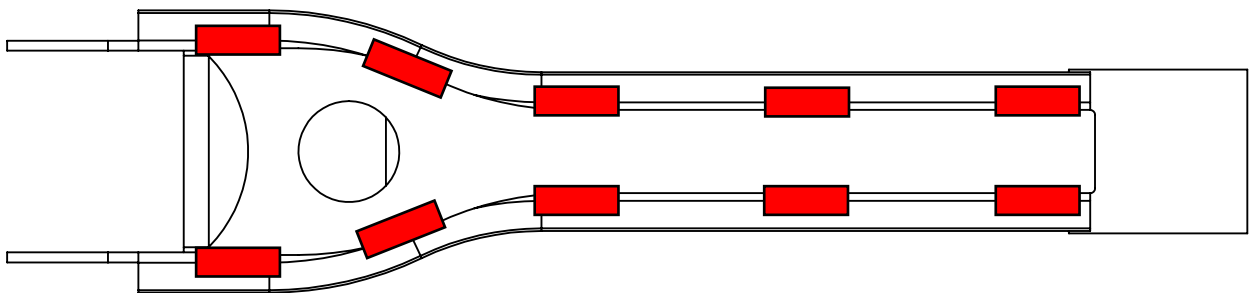

4. Paint the exposed metal to inhibit rust and corrosion. Then re-install your reinforced traction rod.