

# V513-PROX V514-PROX

**NOTE!** S14 S1 comes OEM with a spindle hub washer  
S14 S2/S15 does not use a spindle hub washer  
The GKTECH knuckles have been designed not to use a spindle hub washer  
As such, if you have an S14 S1 the spindle hub washer is to be discarded

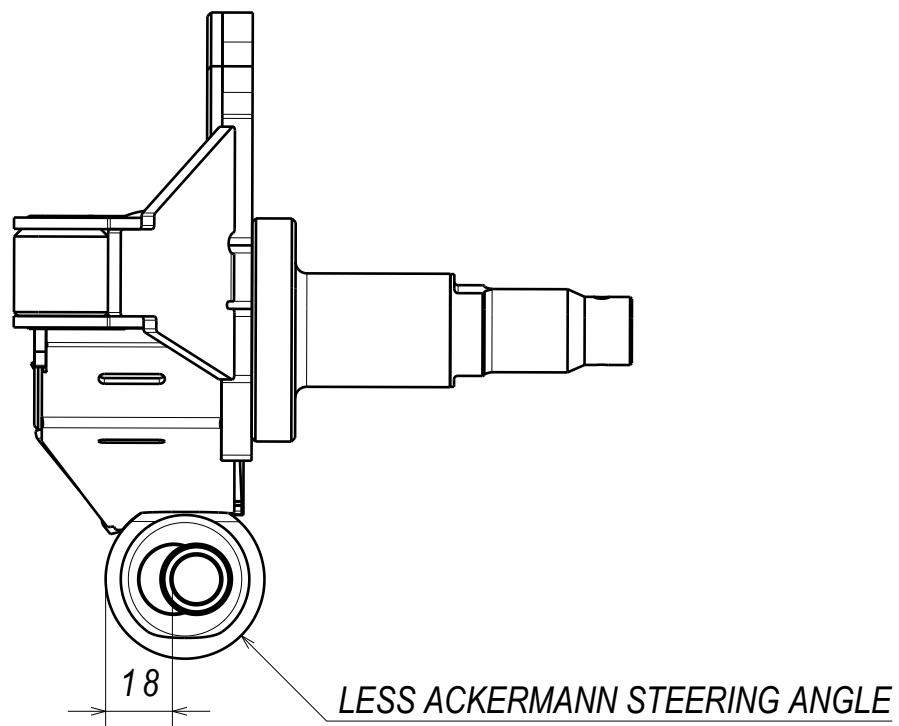
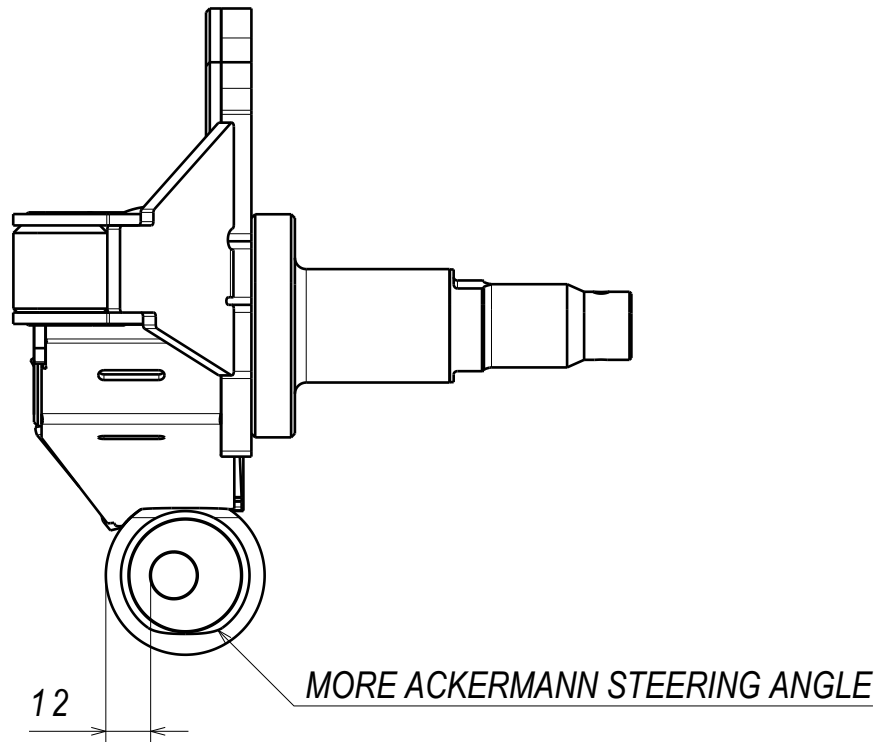

S13 SPINDLE : TIGHEN NUT TO 135 Nm ( 100 lbs-ft)  
S14 SPINDLE: TIGHTEN NUT TO 150 Nm ( 110 lbs-ft)

S13 SPINDLE : TIGHEN NUT TO 190 Nm ( 140 lbs-ft)  
S14 SPINDLE: TIGHTEN NUT TO 240 Nm ( 177 lbs-ft)

FLANGE NUT MUST BE USED

TIGHTEN NUT TO 70 Nm ( 50 lbs-ft)

TIGHEN TO 85 Nm ( 62 lbs-ft)  
(OEM CALIPERS)

TIGHTEN NUT TO 110 Nm ( 82 lbs-ft)

STEERING KNUCKLE

BOTTOM ACKERMANN INSERT

GKtech PRO drift knuckles feature increased  
caster trail and require lower caster than OEM

ALIGNMENT	CASTER ANGLE	CAMBER ANGLE	TOTAL TOE
DRIFTING	4°	-3°..-4°	-2..-4 mm